

CM4

SERIES

**PAGE 6
COMPONENT
MOUNTING CLAMPS**

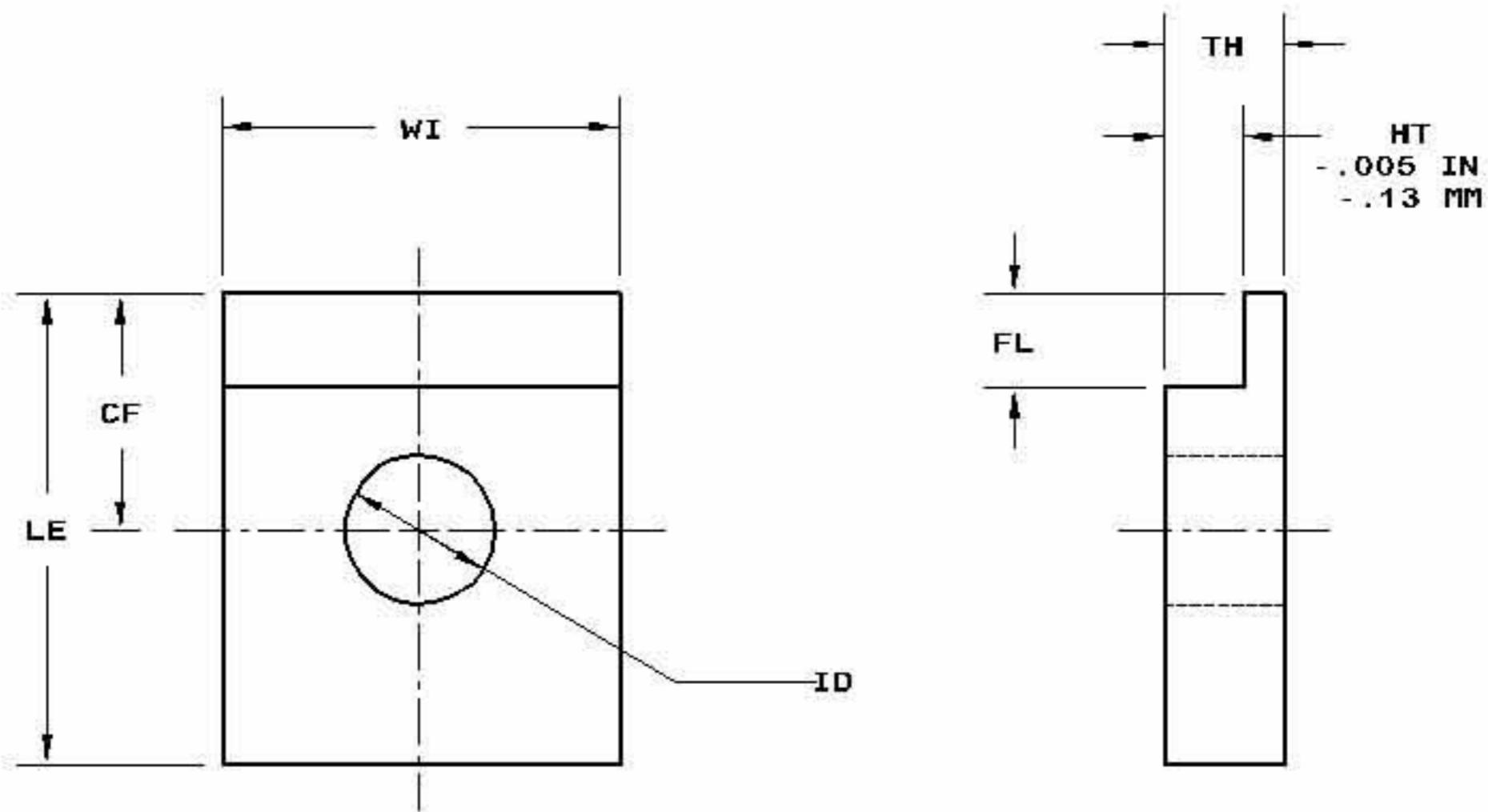

SUFFIX	MATERIAL	FINISH
S	STAINLESS STEEL 303	CLEAR PASSIVATE
F	STAINLESS STEEL 416	CLEAR PASSIVATE

TOLERANCES			
INCH		METRIC	
.XX	±.016	.X	±.4
.XXX	±.005	.XX	±.13
HT	-.005	HT	-.13

CATALOG NO.	HT		TH		LE		WI		FL		CF		ID		
	IN	MM	IN	MM	IN	MM	IN	MM	IN	MM	IN	MM	IN	MM	
CM4-1210.056	S F	.056	1.42	.104	2.64	.203	5.16	.156	3.96	.047	1.19	.125	3.18	.104	2.64
CM4-1218.122	S F	.122	3.10	.187	4.75	.203	5.16	.156	3.96	.047	1.19	.125	3.18	.104	2.64
CM4-1711.078	S F	.078	1.98	.118	3.00	.328	8.33	.218	5.54	.062	1.57	.172	4.37	.125	3.18
CM4-1812.078	S F	.078	1.98	.123	3.12	.375	9.53	.312	7.92	.078	1.98	.182	4.62	.125	3.18

IMPULSE MECHANISMS INC

78-82 N INDUSTRY CT
DEER PARK NY 11729
TEL (631) 586-5755
FAX (631) 586-5757